

Kontakt os for et godt tilbud på  
telefon 30 74 12 02



# LOADMAC

Truck Mounted Forklifts



## FORKING BRILLIANT

Built In The UK | National Service  
Distributed Worldwide | Expert Help & Advice

# WELCOME TO LOADMAC

Our machines are the best. Light and short to improve payload and HGV handling, they are stable even at maximum capacity. There are no complex or unreliable electronics, just tough machines that are easy to operate and maintain, and with our LOADMAC Service Response Backup, you'll never be stuck without a helping hand. Call today and let's get together – there's no obligation, just free advice and information.



**MARK HIGNETT**  
Managing Director



**EXPERT ADVICE** on matching the right machine to your vehicles, products and sites.



**ONE MOUNTING KIT FITS ALL** – An industry innovation! All LOADMAC Truck Mounted Forklifts will travel on ONE mounting kit.



**INTERCHANGEABLE** – in most cases, LOADMAC Truck Mounted Forklifts are interchangeable with your existing mounting kits, regardless of the current make of your TMF.



**BRITAIN'S NO.1** – LOADMAC Truck Mounted Forklifts are the ONLY Truck Mounted Forklifts designed and made in Britain.



**RUSTPROOFED ALL OVER** – LOADMAC are the only Truck Mounted Forklifts with a revolutionary patented PVDC Resin layer of corrosion protection applied all over.



**CHOOSE THE BEST OWNERSHIP OPTION FOR YOU** – You can RENT, CONTRACT HIRE, OR BUY direct from our UK & Global Distributors.



**NATIONWIDE SERVICE** and repairs coverage with LOADMAC throughout the UK.

## THE STORY SO FAR 2006-2016



Established by Mark and Gerry Hignett in 2006. Initially operating out of the UK midlands workshop in Rugby

Company transporter



In 2011, ABT Products in Ross on Wye, UK, was acquired by Mark Hignett and Tim Morris who created ABT Loadmac Limited



July 2012 UK and export deliveries commence



Appointed UK sales & service dealers

2006

2007

2008

2009

2010

2011

2012

2013

2014

2015

2016

Mobile: Area sales managers, fully equipped mobile workshops, and national breakdown coverage

Own mounting kit centre



Full UK sales team



Loadmac 825 Prototype 1



Loadmac 825 Prototype 2



April 2012 Pre Production 1



Market leader in Australia



220 Launch

# APPLICATIONS & FEATURES

## APPLICATIONS

### LOADMAC 220iR

Recycling/Waste collection  
General haulage  
Agricultural feed  
Bottled gas delivery  
Drinks distribution  
RDC/Urban distribution

### LOADMAC 825iSR

Brick and block  
Plasterboard  
Timber  
Turf  
PVC/Steel extrusions  
Fencing  
Events/Marquees

## FEATURES

Integrated Second Reach (iSR) or  
Integrated Reach (iR)  
Multi-Directional (M)  
B-Directional (B)  
2000kg or 2500kg Lift capacity  
825 - 3.1m or 3.6m Lift height mast  
220 – 2.6m, 3.1m or 3.6m Lift height mast  
Short HGV overhang  
Low weight for machine capabilities  
90° Steering lock in both directions  
150mm Side shift  
Rubber mounted cab  
Excellent operator visibility  
Autophoretically rustproofed  
Fits most types of existing mounting kits  
Grommet mounted LED 24v road lights  
Designed & built in Britain



**DO MORE EVERY DAY  
WITH A  
LOADMAC**

# 220iR



1c.

1b.

1a.

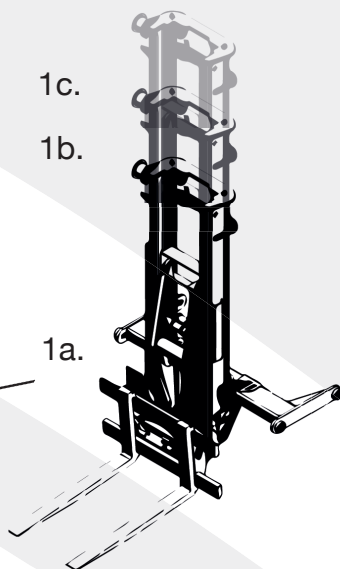

## LIFT HEIGHT OPTIONS

1a. 2600mm

1b. 3100mm

1c. 3600mm

## TYRE OPTIONS

2a. F 27" / R 27"

2b. F 23" / R 27"

2c. F 18" / R 23"

## ENGINE OPTIONS

3a. 29hp 3 Cylinder

3b. 44hp 4 Cylinder Turbo

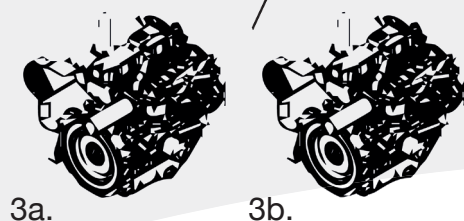

3a.

3b.

2a.

2b.

2c.

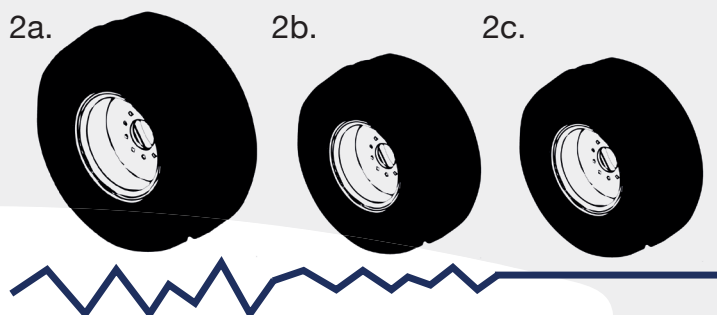

## LOADMAC 220iR

Lifting capacity - 2000kg @ 600mm Load Centre

Engine - 29hp or 44hp Kubota Diesel

Lift height - 2600mm, 3100mm or 3600mm

Steering - Hydrostatic - 90° in both directions

Drive - All wheel hydrostatic drive

Overhang - 1100mm

Overall width - 2160mm

Mast height collapsed - 2200mm

Top speed - 8-12mph / 13-19kph (depends on wheel size)

Ground clearance - 180mm

Unladen weight - 1990kg

Integrated fork positioning option

Telescopic forks option

**LOADMAC TRUCK  
MOUNTED FORKLIFTS**

# 825iSR

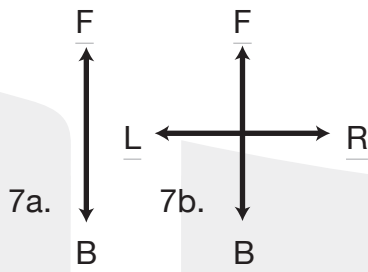

7a.

7b.

4b.

4a.

## LIFT HEIGHT OPTIONS

4a. 3100mm

4b. 3600mm

## TYRE OPTIONS

5a. 10 x 16.5

5b. 280/60

5c. 27 x 10

## ENGINE OPTION

6a. 49hp 4 Cylinder

## MULTI DIRECTIONAL STEERING

7a. B - Direction

7b. Multi - Direction (4 way)

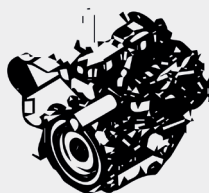

6a.

5a.

5b.

5c.

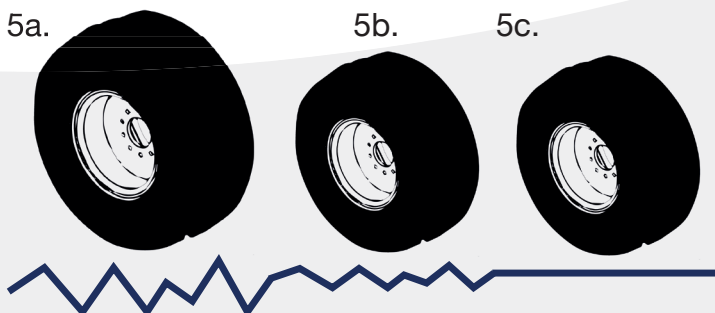

## LOADMAC 825iSR

Lifting capacity - 2500kg @ 600mm Load centre

Engine - 49hp 2200cc Yanmar Diesel

Lift height - 3100mm or 3600mm

Steering - Hydrostatic - 90° in both directions

Drive - All wheel hydrostatic drive

Overhang - 1350mm

Overall width - 2460mm

Mast height collapsed - 2469mm

Top speed - 8mph / 13kph (depends on wheel size)

Ground clearance - 200mm

Unladen weight - 2480kg

Multi-Directional option (M)

Integrated fork positioning option

- More reach
- Better stability
- Faster (un)loading
- Man on the ground mounting
- Better HGV unladen ride characteristics
- True lift capacity